

Architecture and Civil Engineering Faculty
Architecture and Design Department

APPROVED by
Executive Director of KTU
_____Issagulov A.Z.
_____, 2022

REGULATION

on the creative entrance examination
in the discipline "Technical Drawing" for specialty
for specialty 6B07301 Architecture

Regulation on the creative examination has been developed by senior teacher
Abdildina Gulbanu Akhmetzhanovna.

Discussed at the meetings of the Architecture and Design Department

Minutes No. 16 dated 23/03/2022

Acting head of the A&D Department _____ Donenbayev B.S.

INTRODUCTION

Technical Drawing is a subject included in the curriculum of secondary schools of the Republic of Kazakhstan, in which the basic provisions of the theory and practical methods of designing the decoding of graphic images are studied, the ability to draw and correctly execute drawings for a future specialist designer is the most important skill that determines the quality of his future training.

EXAMINATION TASK CONTENT

At the entrance creative exam in technical drawing, the applicant is invited to make a technical drawing of an object in A4 format: according to the visual image of the part, to perform with dimensions, according to the design rules, 3 projections (frontal, horizontal, profile), to build an axonometric projection of the part along the x, y, z coordinate axes (isometric or frontal-dimetric projection).

Four academic hours are allotted to complete the task. The work is performed on sheets of A4 format issued by the Admission Committee and equipped with a special stamp. The examination paper is encrypted; the author's surname is not written on the sheet. The works with indication of the surname and any marks are not evaluated.

CRITERIA PF EVALUATING EXAMINATION WORKS

The finished drawing is evaluated in points according to the following criteria:

40-45 points. Well designed and made drawing. There are no mistakes in the construction of 3 projections of the part (frontal, horizontal profile), the projection connection is observed. Correctly constructed axonometric projection of the part. Dimensioning in the drawing and line types comply with the drawing rules

30-35 points. Well designed and made drawing. There are no mistakes in the construction of 3 projections of the part (frontal, horizontal, profile), the projection connection is observed. Minor mistakes were made in the construction of the axonometric projection of the part.

Dimensioning in the drawing and line types correspond to the rules for the design of drawings.

25-30 points. Compiled and designed drawing. In the construction of 3 projections of the part (frontal, horizontal, profile) there are minor errors, the projection connection is observed. The axonometric projection of the object is not completed. Dimensioning in the drawing and line types correspond to the drawing rules in general.

15-30 points. Compiled and designed drawing. 3 projections were built (frontal horizontal, profile), but there are errors. There are some irregularities in the projection connection. The axonometric projection of the object has not been completed. There are errors in dimensioning on the drawing and in line types.

Less than 10 points. Incorrectly arranged and formatted drawing. 3 projections of the detail (frontal, horizontal, profile) were not built. There is no axonometric projection of the object. There are mistakes in dimensioning on the drawing and in line types.

EXAMINATION TASK
for the creative examination in Technical Drawing
for specialty 6B07301 Architecture

1. Graphic design of A4 format (frame, title block);
2. Based on a visual representation of the part, perform with dimensions, according to the rules for drawing up drawings, 3 projections (frontal, horizontal, profile);
3. Construct an axonometric projection along the coordinate axes x, y, z (isometric or frontal - dimetric projection).

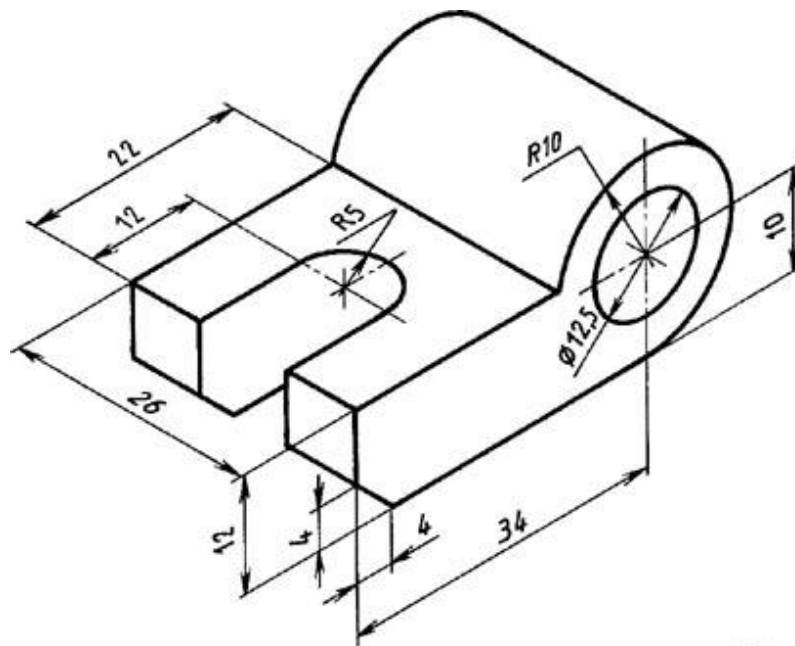

Поводок

List of literature recommended

1. Esmuhan ZH.M. Cherchenie: Uchebnik dlya 9 klassov obshcheobrazovatel'nyh shkol, - Almaty: Izdatel'stvo «Mektep». 2005, 128 s .
2. Kartochki - zadaniya po chercheniyu: 9 kl.: / BB. Stepanova, L.N. Anisimova V.A. Gerver i dr.; Pod red . V.V. Stepakovoj . - M.: Prosveshchenie, 2000. - 64 s., il.